

DC Gear Motor

1.61.042.XXX

Type 1.61.042.XXX

V =	XXX	Characteristics*				max.	Terminal	Stages	Gear
		Rated current	Rated torque	Rated speed	No load speed	Torque*	resistance		ratio
		I_N / A	T_N / mNm	n_N / rpm	n_o / rpm	$T_{\text{max}} / \text{mNm}$	R_a / Ω		
12 V	328	0.540	150	150	218	210	9	3	22.5
	322	0.520	300	64	88	420	9	4	55.5
	323	0.460	600	27	36	840	9	5	137.0
	324	0.280	600	12	14.5	840	9	6	338.0
	325	0.200	600	5.5	5.8	840	9	7	834.0
24 V	341	0.270	150	150	218	210	35	3	22.5
	342	0.260	300	64	88	420	35	4	55.5
	343	0.230	600	27	36	840	35	5	137.0
	344	0.140	600	12	14.5	840	35	6	338.0
	345	0.100	600	5.5	5.8	840	35	7	834.0

Operational conditions

Temperature range	T	°C	-10 - +70
Axial force	F_A	N	15
Radial force, 5 mm from mounting surface	F_R	N	40

* at 25° C

Design	
Weight	180 g
Gear housing	Plastic
Commutator	Copper / 7-segments
RFI protection	2 chokes
Insulation class	Winding H, otherwise A
Protection class	IP40
Commutation	carbon brushes
Armature	straight slot
Magnet system	Permanent magnets, 2-pole
Bearings	2 sintered bronze bearings
Motor housing	Steel, corrosion protected
Motor end shields	brush end plastic drive end zinc die-cast
Spur gear	Metal and plastic gears
Axial play output shaft	0.05 - 0.6 mm



1.61.042.XXX

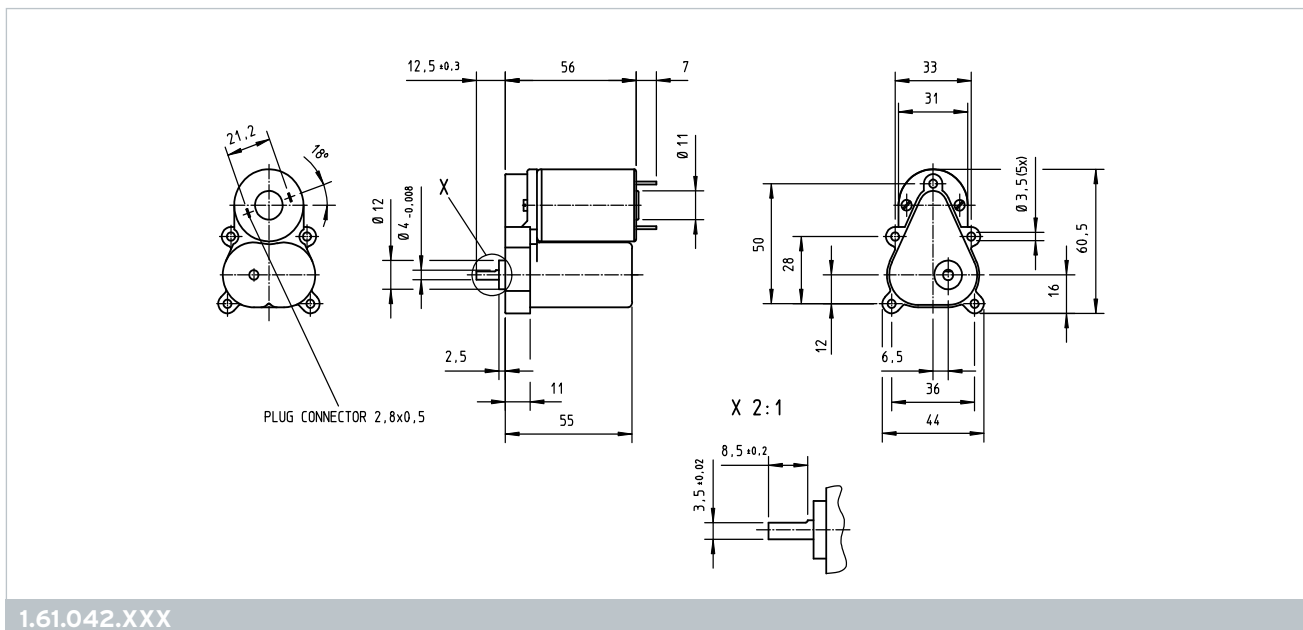

1.61.042.XXX

Customized versions

The following modifications are available upon request:

- ▶ Encoder possible
- ▶ Internal chokes and/or capacitors
- ▶ Speed adjustment by winding change
- ▶ Addition of wire harnesses
- ▶ Modification of shaft length
- ▶ Modification of shaft configuration (flat, groove, etc.)
- ▶ Assembly of gears, pinions, etc.
- ▶ Assembly of adapters and mounting plates
- ▶ Gear ratios $i=2056$ and 5070 on request