

Gearbox Type	Gear Motor Type	A	L
2-stage 2-stufig	1.61.117.310-311 1.61.111.360-361	27.6	75.6
3-stage 3-stufig	1.61.117.312-314 1.61.117.362-364	32.7	80.7
4-stage 4-stufig	1.61.117.315-318 1.61.117.365-368	37.8	85.8

Gear Motor
22 x 75 / 80 / 85
1.61.117.3XX

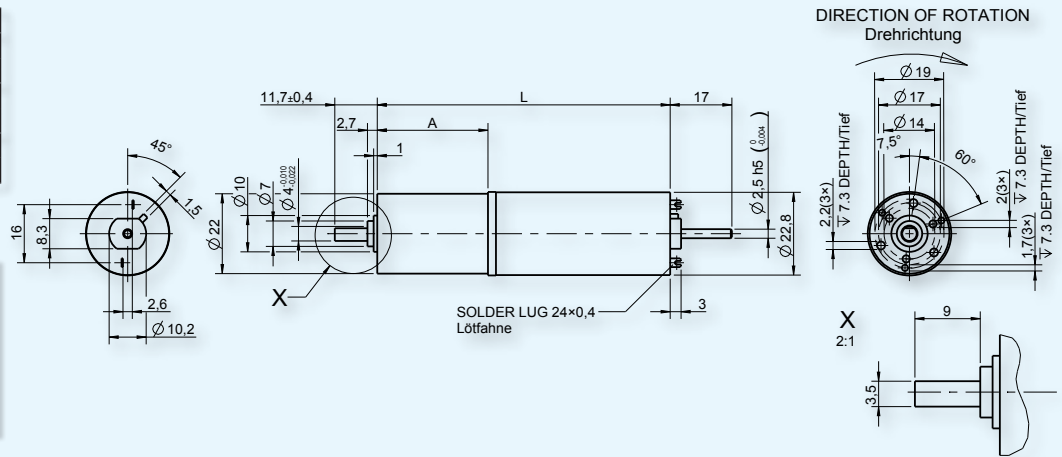

■ Type / Baureihe 1.61.117.XXX

XXX	Characteristics* / Nenndaten*				No load characteristics* / Leerlaufdaten*		Features* / Kenndaten*			
	Rated voltage Nennspannung	Rated current Nennstrom	Rated torque Nenn Drehmoment	Rated speed Nenn-drehzahl	No load speed Leerlauf-drehzahl	No load current Leerlauf-strom	max. Torque max. Drehmoment	Terminal resistance Anschluss-widerstand	Gear ratio Unter-setzungs-verhältnis	Stages Stufen
XXX	U/V / V	I _N / A	T _N /M _N / Ncm	n _N / rpm/min ⁻¹	n ₀ / rpm/min ⁻¹	I ₀ / A	T _{max} /M _{max} /Ncm	R / Ohm	i	

310	12	0.720	15	205	301	0.200	30	6.7	19.2	2
311	12	0.660	20	145	203	0.200	30	6.7	28.4	2
312	12	0.580	35	65	82	0.200	60	6.7	69.1	3
313	12	0.490	40	47	55.5	0.200	60	6.7	102	3
314	12	0.380	40	34	37.5	0.200	60	6.7	152	3
315	12	0.360	45	21	22.5	0.200	80	6.7	249	4
316	12	0.320	50	15	15	0.200	80	6.7	369	4
317	12	0.290	60	10	10	0.200	80	6.7	546	4
318	12	0.260	65	7.0	7.0	0.200	80	6.7	809	4

360	24	0.360	15	205	301	0.100	30	27	19.2	2
361	24	0.330	20	145	203	0.100	30	27	28.4	2
362	24	0.290	35	65	82	0.100	60	27	69.1	3
363	24	0.240	40	47	55.5	0.100	60	27	102	3
364	24	0.190	40	34	37.5	0.100	60	27	152	3
365	24	0.180	45	21	22.5	0.100	80	27	249	4
366	24	0.150	50	15	15	0.100	80	27	369	4
367	24	0.140	60	10	10	0.100	80	27	546	4
368	24	0.130	65	7.0	7.0	0.100	80	27	809	4

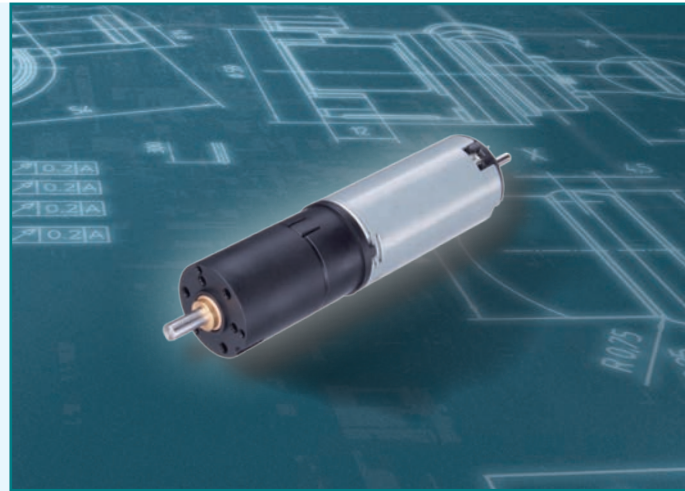

Design	
Gear housing	Plastic
Commutator	Copper / 3-segments
RFI protection	Suppression disk; 2 capacitors
Insulation class	Winding F, otherwise A
Protection class	IP20
Commutation	Carbon brushes
Armature	straight slot
Magnet system	Permanent magnets, 2-pole
Bearings	2 sintered bronze bearings
Motor housing	Steel, corrosion protected
Motor end shields	brush end plastic, drive end zinc die-cast
Planetary gear	Plastic gears
Life expectancy**	up to 600 h
Weight	90 - 100 g
Axial play output shaft	0.05 - 0.6 mm

Aufbau	
Getriebegehäuse	Kunststoff
Kollektor	Kupfer / 3-teilig
Grundentstörung	Entstörscheibe; 2 Kondensatoren
Isolierstoffklasse	Wicklung F, ansonsten A
Schutzart	IP 20
Kommutierung	Kohlebürsten
Anker	gerade Nut
Magnetsystem	Permanentmagnete, 2-polig
Motorlager	2 ölgetränkte Sinterbronzelager
Motorgehäuse	Stahl, korrosionsgeschützt
Motorlagerschilde	kollektorseitig Kunststoff, abtriebsseitig Zinkdruckguss
Planetengeräte	Zahnräder aus Kunststoff
Lebensdauer**	bis 600 h
Gewicht	90 - 100 g
Axialspiel Abtriebswelle	0.05 - 0.6 mm

Operational conditions*	Einsatzbedingungen*			
Temperature range***	Temperaturbereich***	T	°C	-10 - +70
Axial force	Axialkraft	F _A	N	8
Radial force, 5 mm from mounting surface	Radialkraft, 5 mm ab Anschraubfläche	F _R	N	15

* at 25 °C

** depending on the operating conditions

*** extended temperature range on request

* bezogen auf 25 °C

** abhängig von den Einsatzbedingungen

*** erweiterter Temperaturbereich auf Anfrage