

# DC Motor

□ 90mm  
D940-30B3(24V)



## Standard Features

- Adjustable speed and starting torque
- Replaceable brushes
- Different voltage and speed ratings available
- Models with accessory shaft for mounting a brake, encoder or double ended motor shaft
- Special making as per customer requirement is possible



## Typical outline drawing

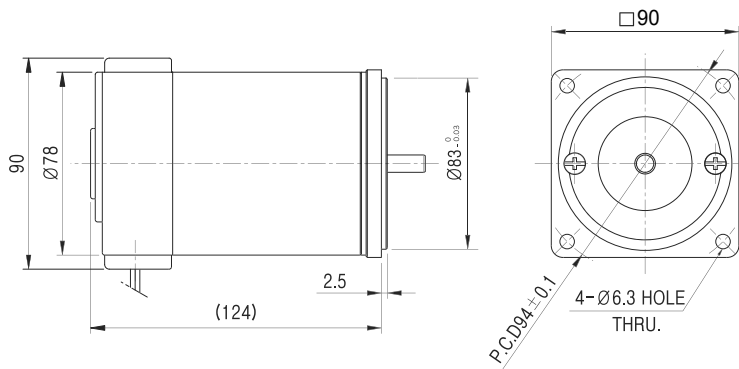

[www.MuGuL.com](http://www.MuGuL.com)

## Performance curve

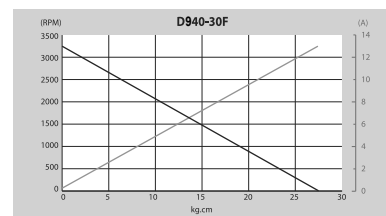
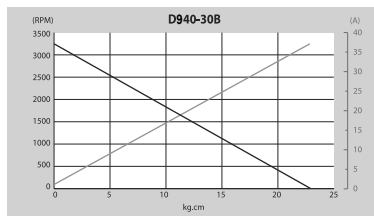
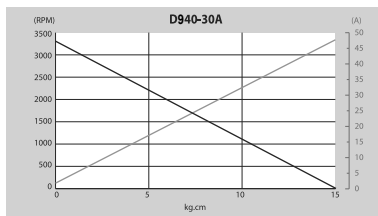

## Specification

MODEL NO.	Voltage (V)	No Load			Rated Load			Stall	
		Speed (r/min)	Current (A)	Output (W)	Speed (r/min)	Torque (kgf-cm)	Current (A)	Torque (kgf-cm)	Current (A)
D940-30A	12	3300	1.5	37	3000	1.3	4.8	15	47
D940-30B	24	3250	0.6	37	3000	1.3	1.5	23	37
D940-30F	90	3400	0.2	37	3000	1.3	0.6	24	13

□ 90mm  
D9HK□□□



**Standard Features**

- High Precision, High Efficiency and High Reliability
- Wider varieties for gear ratios and shaft arrangements
- Special making as per customer requirement is possible

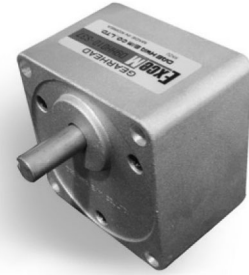

**Typical outline drawing**

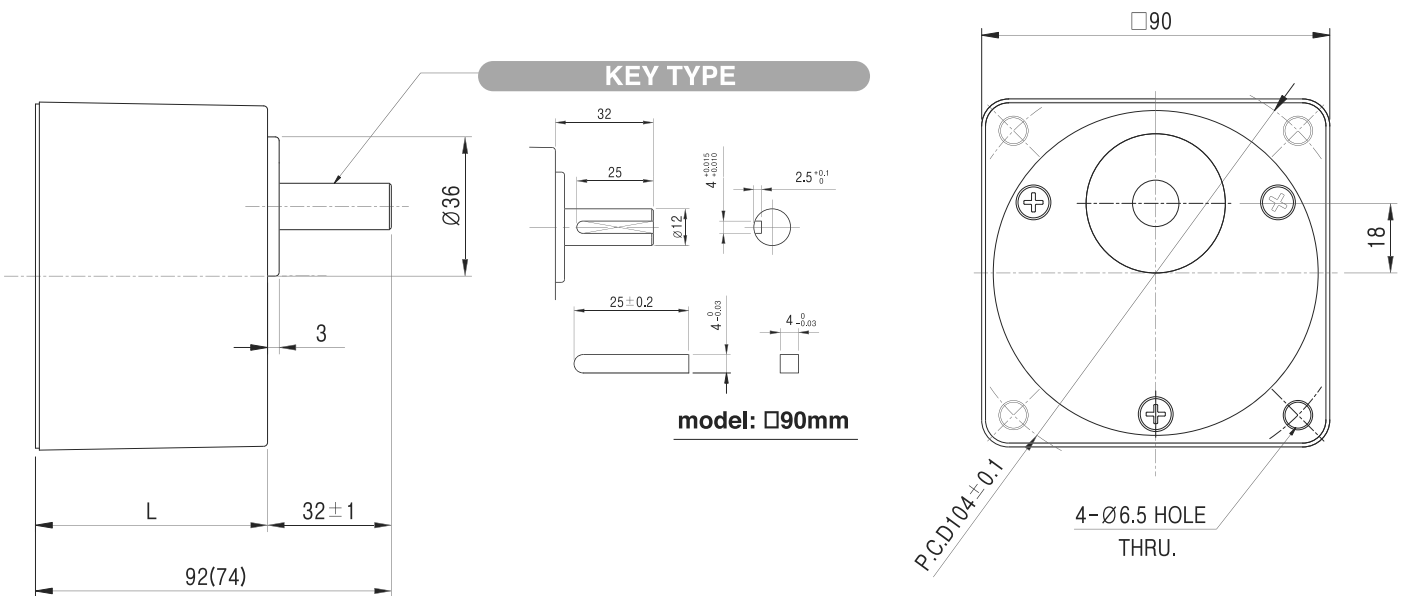

Gear Ratio	L
3 ~ 18	42
20 ~ 250	60

[www.MuGuL.com](http://www.MuGuL.com)

**Specification**

**PERMISSIBLE OVERHUNG LOAD AND PERMISSIBLE THRUST LOAD**

Model	Gear Ratio	Permissible overhung load kgf	Permissible thrust load kgf
D9HK □ D9HD □ D9HS □	3 ~ 18	30	10
	20 ~ 200	37	

**Maximum permissible torque**

UNIT=kgf · cm

Gear Ratio / Model	3	3.6	5	6	7.5	9	10	12.5	15	18	20	25
D960-30 □	54.2	65.0	90.3	100	100	100	100	100	100	100	100	100
D990-30 □	82.7	99.2	100	100	100	100	100	100	100	100	100	100

Gear Ratio / Model	30	36	40	50	60	75	90	100	120	150	180	200
D960-30 □	100	100	100	100	100	100	100	100	100	100	100	100
D990-30 □	100	100	100	100	100	100	100	100	100	100	100	100

**Rotation Direction Output shaft Gearbox**

**Rotation Direction as per Gear Ratio**

Gear Ratio / Model	3	3.6	5	6	7.5	9	10	12.5	15	18	20	25	30	36	40	50	60	75	90	100	120	150	180	200
□90mm	■	■	■	■	■	■	■	■	■	■	■	■	■	■	■	■	■	■	■	■	■	■	■	■

■ The same direction with motor      ■ The reverse direction with motor