

90mm sq(3.54in.sq)
D91F-30B(24V) / D91F-30F(90V)



Standard Features

- Adjustable speed and high starting torque
- Replaceable brushes
- Different voltage and speed ratings available
- Models with accessory shaft for mounting a brake, encoder or double ended motor shaft
- Special making as per customer requirement is possible



Typical outline drawing

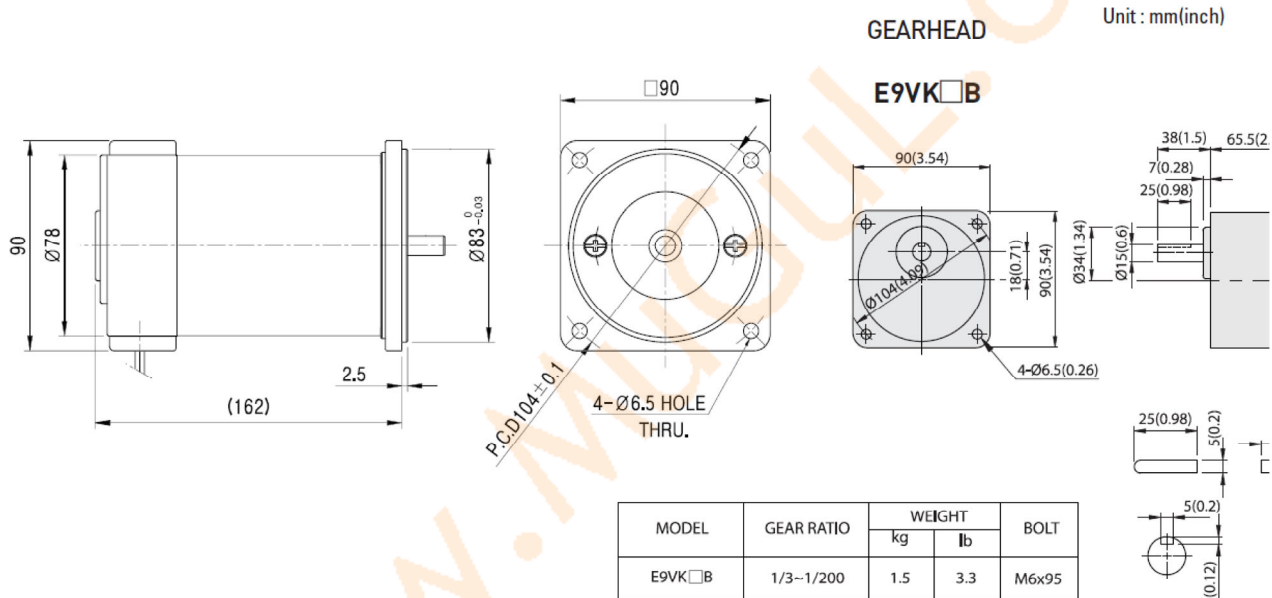

KEY SIZE

Performance curve

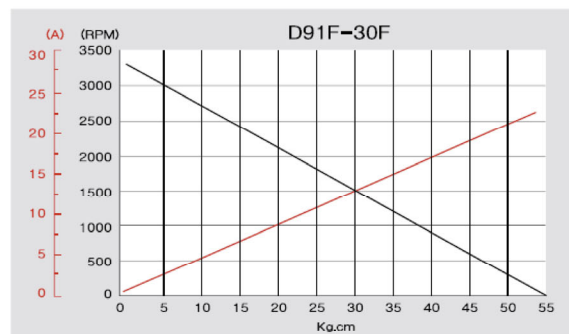
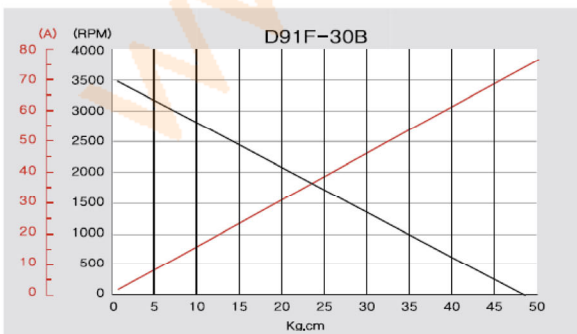

Specification

MODEL NO.	Voltage (V)	No Load			Rated Load			Stall	
		Speed (r/min)	Current (A)	Output (W)	Speed (r/min)	Torque (kgf-cm)	Current (A)	Torque (kgf-cm)	Current (A)
D91F-30B	24	3400	1.8	150	3000	4.87	8	48	78
D91F-30F	90	3200	0.5	150	3000	4.87	2	52	23